 <p>AUSTRALIAN STEEL INSTITUTE (ABN)/ACN (94) 000973 839 www.steel.org.au ASI TECHNICAL NOTE TN012 V1</p>	REF: ASI TN012 Version 1	
	ASI Head Office Level 13, 99 Mount Street North Sydney NSW 2060 Tel: 02 9931 6666 Email: enquiries@steel.org.au	
	Author: P.W.KEY	
	Date: Feb 2015	Page 1 of 12

DESIGN OF BOLTED ANGLE CLEAT CONNECTIONS - A FABRICATION RESPONSIVE SOLUTION

SUMMARY

This Technical Note is intended to provide guidance on the case for adoption of bolted angle cleat connections and the particular design aspects that are relevant to the available connection models, allowing designers to identify the most appropriate use cases for the connection. Detailed design models are referenced to those available in other ASI publications.

It is recommended that designers provide suitable notes on their drawings to allow alternative connection designs, such as the bolted angle cleat, as this will ensure cost effective solutions that are responsive to the current market dynamics.

INTRODUCTION

Cost effective processes in the fabrication industry are in a continual state of flux, responsive to often contradictory market forces including labour rates, the construction cycle, workplace health and safety, the process technology available and the cost to implement efficiency improvements. Preferred or economic solutions for particular steel connection details are subject to these same market forces, which inevitably results in certain steel connection details becoming more cost and process effective than others at certain points in time.

Efficiencies in cost and fabrication time with the use of structural steel can be provided in design by adopting a collaborative approach with the fabricator. The type of steel processing methods and equipment, specifically around connection design, can make significant differences to structural cost. A steel fabricator without a Computer Numerically Controlled (CNC) beam line and CNC angle line equipment may favour welded cleat plate connections, whereas a fabricator with substantial CNC processing equipment will often be able to make significant savings utilising predominantly bolted connections, taking advantage of the automated holing and coping by CNC machines. A collaborative approach to connection design between designer and fabricator will facilitate the potential for efficient solutions. In the UK and USA, connection design is usually handled by the fabricator's engineer for this very reason.

The bolted angle cleat connection is a case in point and in recent years, with change and improvement in fabrication technology and supply chain logistics, has become a solution that is responsive to CNC fabrication economies and/or pre-processing by steel processors and distributors.

THE BOLTED ANGLE CLEAT CONNECTION

The bolted angle cleat connection consists of either a single angle bolted to a supported member web or two angles bolted each side of a supported member web. The angle or angles are in turn bolted to the supporting member. Typical examples of connection configurations are shown in Figure 1.

DISCLAIMER: *The Australian Steel Institute Limited shall not be liable or responsible in any way whatsoever and expressly disclaims any liability or responsibility for any loss or damage, claim, proceedings costs or expenses howsoever incurred by any person whether the client or any third party and whether accruing under statute or in negligence, contract or otherwise at common law, including but without in any way limited to any loss or damage, claim proceedings costs or expenses incurred as a result of or in connection with the reliance whether whole or partial by any person as aforesaid upon any part of the contents of this advice.*

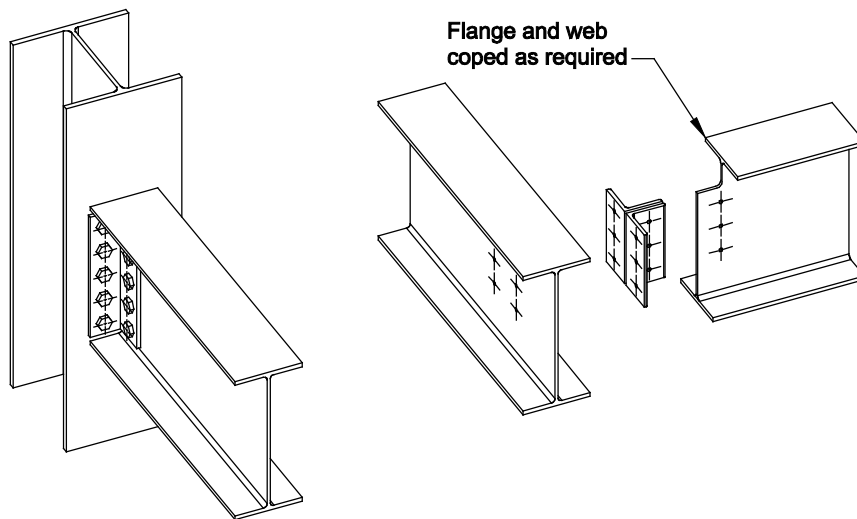

FIGURE 1 TYPICAL SINGLE AND DOUBLE BOLTED ANGLE CLEAT CONNECTIONS

The bolted angle cleat connection is distinctly different, but used for similar connections, to the web side plate connection and flexible end plate connection, both shown in Figure 2. Significantly, the bolted angle cleat connection contains no welded elements, which is the core differentiator that may enable efficiencies in the fabrication process and supply chain, as will be discussed subsequently.

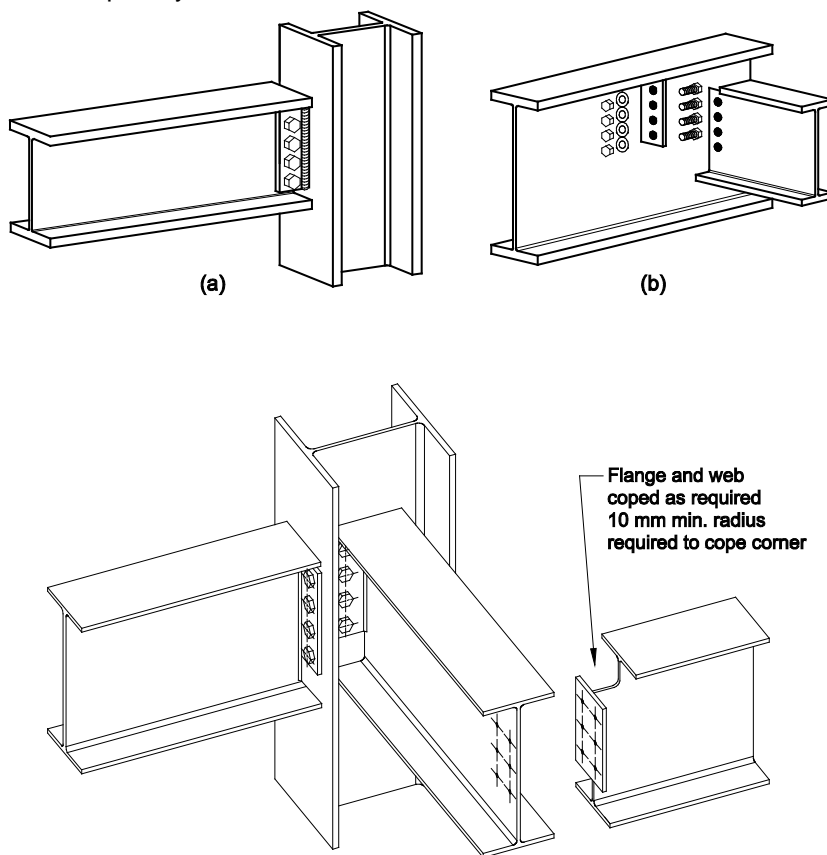

FIGURE 2 TYPICAL WEB SIDE PLATE AND FLEXIBLE END PLATE CONNECTIONS

THE STRUCTURAL STEELWORK SUPPLY CHAIN

The overall structure of the structural steelwork supply chain in Australia is reasonably well established and is shown diagrammatically in Figure 3. 'Stick' steel sections (hot-rolled open sections and cold-formed structural hollow sections) and plate steel are produced by the steel mills and shipped to distributors, who maintain a stock of the most popular sizes of sections and plate and will order any material not held in stock from the mills to meet procurer requirements. The procurer would usually be a fabricator, who fabricates the sections and plate into components as defined in the contractual documents for the project. The contractor commissions the fabricator to produce (and often erect) the structural steelwork components for the project. A number of contractual permutations are possible around this basic workflow.

Opening up of markets through globalisation has resulted in increased avenues for importation of steel and steelwork at various points in the supply chain, as also shown in Figure 3. Non-compliant construction products have become a significant issue (Ref. 1) and the development of the National Structural Steelwork Compliance Scheme (NSSCS) by ASI is a response to manage steelwork quality in Australia (Ref. 2 and 3).

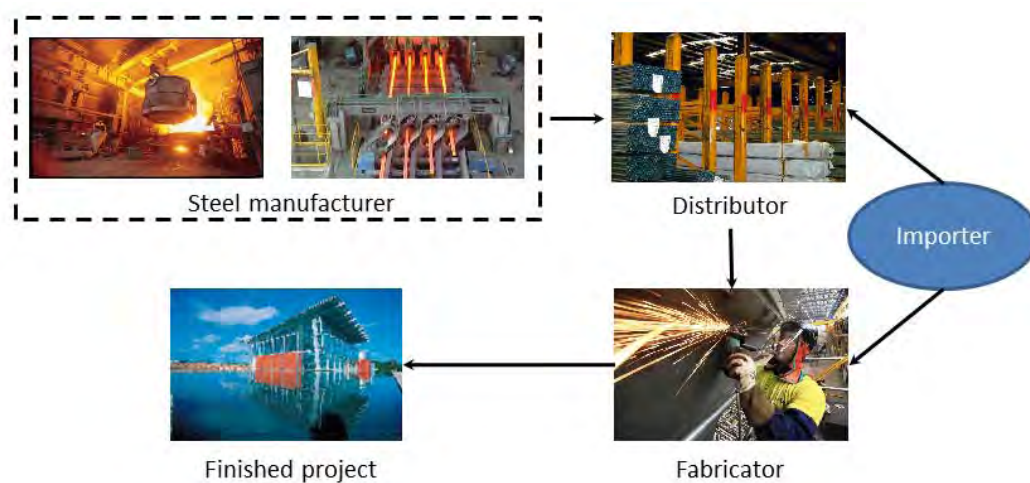

FIGURE 3 GENERIC STEELWORK SUPPLY CHAIN IN AUSTRALIA

CHANGES IN THE STEEL AND STEELWORK SUPPLY CHAIN

Increasingly in recent years, distributors, whose traditional role has been to simply stock and distribute the raw sections and plate from the mills, have undertaken a degree of 'pre-processing' of the stock steel to provide value-added services for clients. Typical pre-processing of steel includes:

- Cutting steel sections to exact lengths required
- Drilling of steel sections for bolted connection holes
- Coping of steel sections to suit connection details

These operations are performed by single or combinations of machines often generically referred to as 'beam lines'. Typical examples of beam line components are shown in Figure 4. A range of videos on fabrication processes are viewable from the ASI website at <http://steel.org.au/member-resources/student-resources-members/steel-fabrication/>



FIGURE 4 TYPICAL BEAM LINE COMPONENTS

For standard operations that involve 'mechanical' fabrication operations (holing, cutting, edge treatment etc.), beam lines may offer a cost effective solution, provided economies of scale can offset the up-front installation cost. For many fabricators, in particular those who do not have appropriate CNC equipment, it may make economic sense to subcontract these pre-processing services out to the steel distributor or steel processor and receive steel components that, in some cases, do not require any further fabrication.

POTENTIAL COST SAVINGS IN STEELWORK FABRICATION AND ERECTION

A 2011 report commissioned by ASI and undertaken by Rider Levett Bucknall (RLB) and titled 'Review of steel costs in medium rise steel framed buildings' (Ref. 4) clearly indicated there was potential for cost savings in a number of areas of steelwork fabrication and erection, including:

1. Reduction or elimination of in-house fabrication/processing where the distributor/merchant can pre-drill and cut members to size
2. Where machine fabrication could be utilised for most items
3. Shop drawing requirements where repetition of member types was possible
4. On-site erection due to all connections being bolted rather than welded
5. Connection costs where connections could be simplified and repetitive

The message around the option to utilise fully bolted connections where possible and maximising the potential for cost effective pre-processing by distributors where appropriate is clear. Numerous connection models published by ASI, including Refs 5 and 6, all adopt standardised connection detailing to support ease of fabrication (and of pre-processing).

The bolted angle cleat connection is a straightforward application of a number of the abovementioned principles and has the potential to contribute to cost effective solutions, in particular for scenarios where there are repetitive simple connections, as is usually the case for the structural beams in multi-storey building construction.

FABRICATION EFFICIENCY

A simple comparison provides an indication of the relativity in fabrication efficiency between welded and bolted angle cleats. The 610UB101 beam member shown in Figure 5(b) has six cleats welded to the web (three each side) intended to accept bolted secondary beams. The total fabrication and weld time for this beam is nominally six hours. The functionally equivalent beam shown in Figure 5(a) has holing for six bolted angle cleats (three each side). The total fabrication time for this beam is one hour. Additionally, if pre-processing of the beam (and potentially also the angle cleats) is undertaken by the distributor, then the fabricator has potentially only nominal time exposure on this element.

The comparison does not consider the additional time necessary for cutting and holing of the angle cleats or assembly of the bolted cleats to the supporting beam in option (a). Depending on specific erector preferences, pre-assembly of the bolted cleats to the supporting beams in the fabrication shop may be preferable.

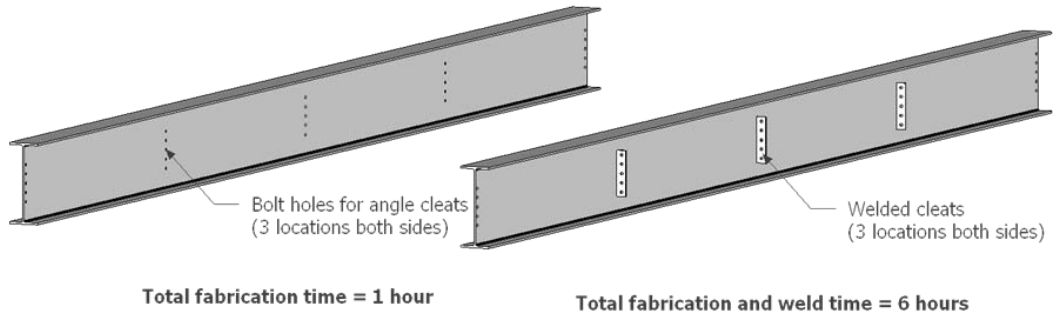

(a) Bolted angle cleats

(b) Welded cleats

FIGURE 5 COMPARISON OF FABRICATION TIME FOR WELDED CLEATS VERSUS BOLTED ANGLE CLEATS

Information on steel costs and fabrication efficiencies, in particular in relation to multistorey buildings, is available from the ASI website at <http://steel.org.au/key-issues/multilevel-buildings/steel-costs/>.

TYPICAL DETAILING OF BOLTED ANGLE CLEAT CONNECTION

The typical detailing of the bolted angle cleat connection for both single angle and double angle cleats is shown in Figure 6, with the standardised designation of dimensioning indicated.

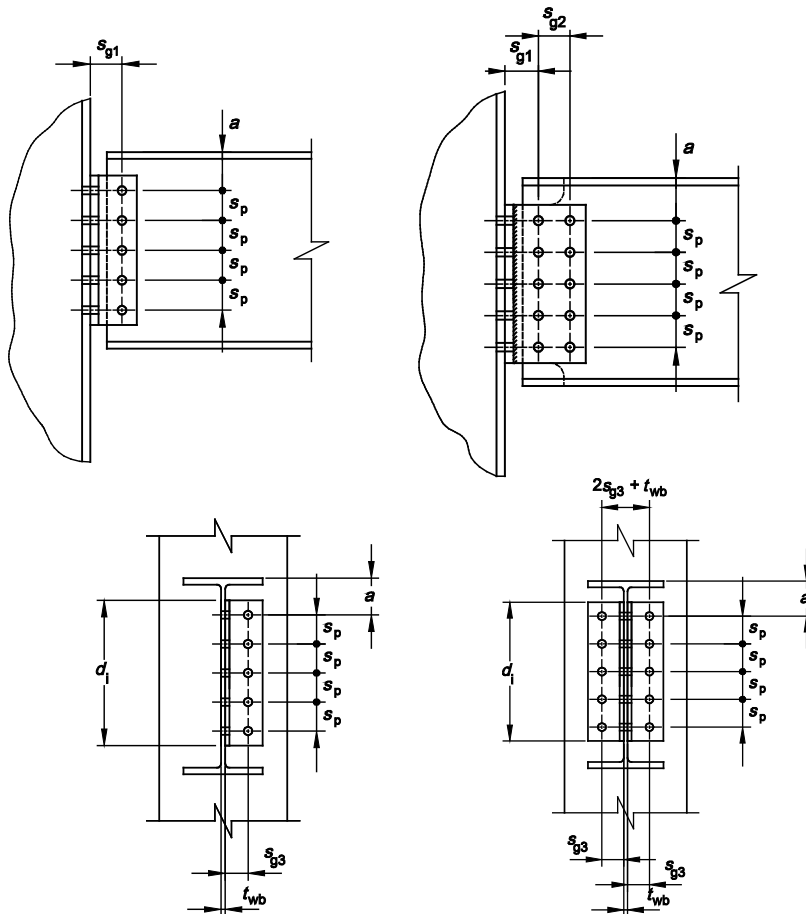

FIGURE 6 TYPICAL DETAILING FOR SINGLE AND DOUBLE BOLTED ANGLE CLEAT CONNECTIONS

Considerations in respect of detailing include:

- 1 The angle component is a standard rolled equal or unequal angle (Grade 300). The component is usually cropped or oxy-cut to length and the holes are usually punched. Limitations in AS 4100 Section 14 (Ref. 7) apply to these operations.
- 2 Raking beams can be accommodated with some attention to detail. Skew beams cannot easily be accommodated.
- 3 Bolt holes are 2 mm larger than the nominal bolt diameter. Slotted or oversize holes are not used because AS 4100 requires the use of either bolting category 8.8/TF or 8.8/TB for such hole types.
- 4 In connections to column webs, the beam flange may also need to be coped (removed) to allow the connection to be effected (Figure 7).
- 5 Fabrication of this type of connection requires close control in cutting the beam to length and adequate consideration must be given to squaring the beam ends such that both angle cleats are parallel and the effect of beam camber does not result in out-of-square angle cleats which makes erection and field fit-up difficult.
- 6 The use of this connection for two-sided beam-to-beam connections should be considered carefully. Installation of bolts in the supporting member can cause difficulties in this case. When unequal sized beams are used, special coping of the bottom flange of the smaller beams may be required to prevent it fouling the bolts (Figure 8).
- 7 The connection has some facility for site adjustment during erection. In a run of beams, a slightly shorter beam may be detailed and supplied with packs of varying thickness in order to take up any accumulation of tolerances.
- 8 For coped beams, the top of the end plate and the bottom of the top flange cope cut should coincide.
- 9 Check angle cleat component width to ensure that it will fit between fillets of column section when connecting to column web (Figure 7).
- 10 In connections to column webs, a check must be made on the length of bolt to be used to ensure sufficient clearance is available between the angle cleat and the inside of the column flange, to permit the bolts to be installed (Figure 7).
- 11 Erection clearances must be especially considered because of the necessity to angle beams into place during erection. This consideration is most important for the case of a series of beams in the one row, all connected between the same main supporting members.
- 12 If beams of different web thickness are connected to opposite sides of a supporting member web (column or beam), the difference in web thickness must be kept to 2 mm to allow the bolt gauge to be set to suit both supported member webs.
- 13 The bolt gauge for double angle cleat connections is usually set at around 140 mm with s_{g3} set at 65 mm. This will accommodate web thicknesses from 6 mm to 14 mm, which caters for most rolled section supported members.
- 14 The angle cleat is a good connection in terms of its facility for site adjustment. The two sets of bolts are both placed in clearance holes allowing slight adjustment in two directions before the bolts are tightened. In addition to this, packs can be placed between the cleats and the supported member if required.
- 15 With two sided connections that share a common set of bolts, the shop bolts (or site bolts) should be placed with heads in opposite directions in the webs of the connecting pair of beams and the site bolts placed as shown in Figure 8. In some cases, it may be necessary to place the nut over the hole and turn the bolt into the nut.

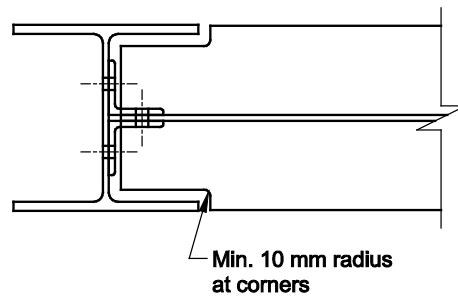

FIGURE 7 COPING BEAM FLANGE(S) FOR COLUMN WEB CONNECTION

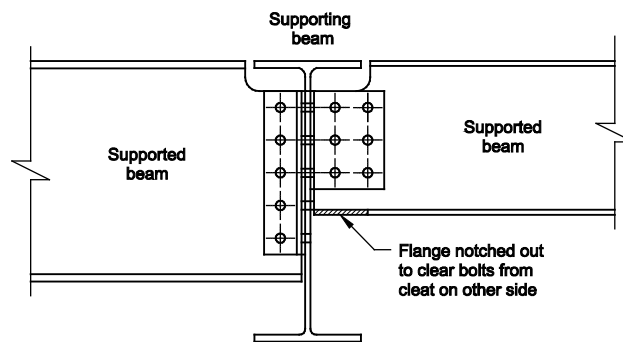
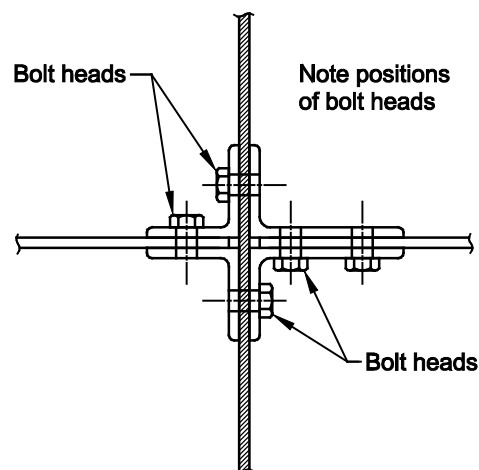

FIGURE 8 COPING BEAM BOTTOM FLANGE TO CLEAR BOLTS

FIGURE 9 TYPICAL BOLT PLACEMENT
(after Ref. 8)

COMPLIANCE WITH AS 4100 REQUIREMENTS FOR CONNECTIONS

The angle cleat is notionally a FLEXIBLE CONNECTION within the terms of AS 4100, which is discussed in Section 2.2 of Handbook 1 (Ref. 9). The requirements for any design model are specified in Clause 9.1.3 of AS 4100 (Ref. 7) which is discussed in Section 2.3 of Handbook 1.

The ductility necessary in the angle cleat connection is provided by the following factors:

- deformation of the bolts along their axis;
- deformation of the angle cleat by flexing out of plane, pulling in towards the beam and local deformation of the cleat around the bolt (Figure 10);

— slippage of the cleat horizontally as the plate deforms.

It is considered that the available testing data indicate that sufficient ductility is present from these sources for the angle cleat connection to qualify as suitable for simple construction terms of the requirements of AS 4100, provided that all the requirements of this design model—particularly the limitation on supported member rotation and the geometrical limitations specified—are complied with.

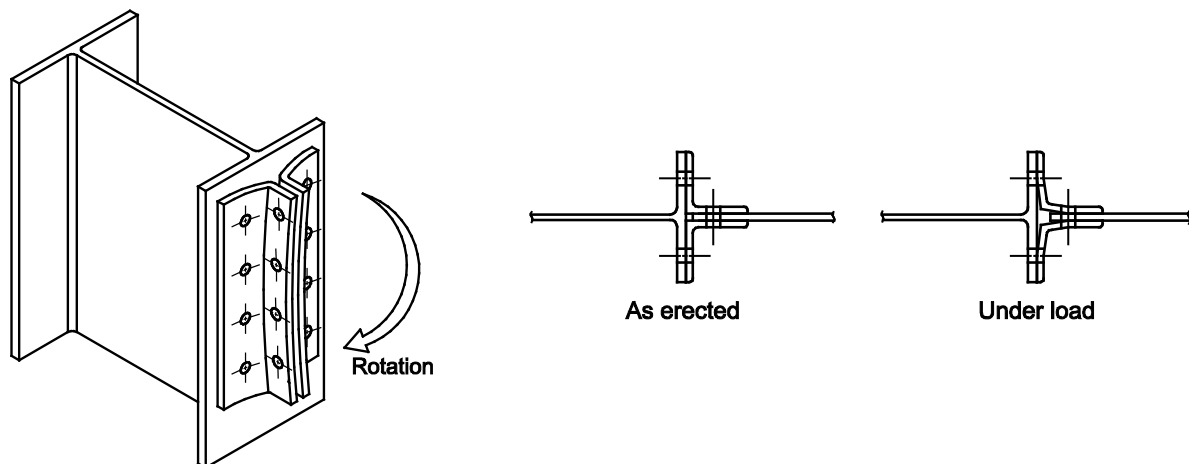

FIGURE 10 DEFORMATION OF THE ANGLE CLEAT
(after Ref. 10)

BASIS OF DESIGN MODEL – DOUBLE ANGLE CLEATS

The recommended design model in this Design Guide treats the angle cleats as an extension of the supported beam web.

The American Institute of Steel Construction (Ref. 8) and the Steel Construction Institute, UK (Ref. 10) adopt a similar design model, with similar assumptions to the recommended design model.

The design capacity of the bolt group connecting the angle cleats to the supporting member is based on the assumption that the bolts are loaded in vertical shear only. The design expression is based on Section 3.6 of Handbook 1 (Ref. 9).

The design capacity of the bolt group connecting the angle cleats to the supported member is based on the assumption that the bolt group is subject to eccentric shear force acting at the face of the supporting member. The design expression is based on Section 3.9 of Handbook 1 and involves consideration of the following:

- (i) the bolt group being loaded in eccentric shear with the design capacity being derived using the method of Section 3.9 of Handbook 1, this design capacity being limited by the bolt shear capacity, bearing on the component and on the supported member web (even though hole distortion is an inherent part of providing rotational ductility in the connection).
- (ii) end plate tear-out at the most heavily loaded bolt being checked using the component of force in the vertical direction with any end distances (including holes) in the vertical direction and the component of force in the horizontal direction with any end distances in the horizontal direction. The expressions on which the design capacity are based are also derived in Section 3.9 of Handbook 1.

The expressions for the design capacities of the angle cleat component in shear and under moment are taken directly from the expressions given in Section 5.4 of Handbook 1, the latter being derived from the design moment capacity (ϕM_{si}) divided by the eccentricity (e). Likewise, the expression for the design capacity in block shear is taken from Section 5.4 of Handbook 1.

The design capacity of the supported member in shear and in bending for coped supported members use the expressions derived in Section 6.2 to 6.6 of Handbook 1, again assuming that the end reaction acts at the face of the supporting member. The design capacity in block shear is intended to guard against the possibility of that type of failure in the web of a coped supported member. This phenomenon is discussed in detail in Section 6.9 of Handbook 1.

In Reference 11, Carrato has compared Australian (Ref. 12) and American (Ref. 13) design methods. He observed that the Australian method gave a lower design capacity and noted that this is primarily due to consideration of horizontal tear-out in the web of the supported member in the Australian design method. Carrato considers such tear-out as 'highly unlikely' for five different reasons. The other minor differences between the two design methods noted by Carrato are considered by him not to influence 'the final design of the connection'.

Since the bolts in the supported member web are considered to be eccentrically loaded in the recommended design model of Reference 12 and this Design Guide, a horizontal component of force is applied to the bolts. AS 4100 requires that tear-out be considered in such a case. The basis of the recommended design model in this Design Guide is consequently identical to that in Reference 12, and is consistent with that for the web side plate connection in this respect as contained in Handbook 1.

BASIS OF DESIGN MODEL – SINGLE ANGLE CLEATS

The recommended design model in this Design Guide treats the angle cleat as an extension of the supported beam web.

The American Institute of Steel Construction (Ref. 8) adopts a similar design model, with similar assumptions to the recommended design model. The Steel Construction Institute, UK (Ref. 10) does not have a design model for a single angle cleat.

The design capacity of the bolt group connecting the angle cleat to the supporting member is based on the assumption that the bolts are loaded in eccentric shear force. The design expression is based on Section 3.9 of Handbook 1 (Ref. 9) for an eccentricity equal to the distance between the centre of the supported member web and the centre of the bolt group.

The design capacity of the bolt group connecting the angle cleat to the supported member is based on the assumption that the bolt group is subject to eccentric shear force acting at the face of the supporting member. The design expression is based on Section 3.9 of Handbook 1.

The design expressions for both bolt groups involves consideration of the following:

- (i) the bolt group being loaded in eccentric shear with the design capacity being derived using the method of Section 3.9 of Handbook 1, this design capacity being limited by the bolt shear capacity, bearing on the component and on the supported member web (even though hole distortion is an inherent part of providing rotational ductility in the connection).
- (ii) end plate tear-out at the most heavily loaded bolt being checked using the component of force in the vertical direction with any end distances (including holes) in the vertical direction and the component of force in the horizontal direction with any end distance in the horizontal direction. The expressions on which the design capacity is based are also derived in Section 3.9 of Handbook 1.

The expressions for the design capacities of the angle cleat component in shear and under moment are taken directly from the expressions given in Section 5.4 of Handbook 1, the latter being derived from the design moment capacity (ϕM_{si}) divided by the eccentricity (e). Likewise, the expression for the design capacity in block shear is taken from Section 5.4 of Handbook 1.

The design capacity of the supported member in shear and in bending for coped supported members use the expressions derived in Section 6.2 to 6.6 of Handbook 1, again assuming that the end reaction acts at the face of the supporting member. The design capacity in block shear is intended to guard against the possibility of that type of failure in the web of a coped supported member. This phenomenon is discussed in detail in Section 6.9 of Handbook 1.

CONNECTION GEOMETRY

As indicated in Figure 11, angle components are assumed to be oriented such that:

- (a) one leg of the angle cleat component (leg α) is attached to the supporting member through bolt group α ;
- (b) the other leg of the angle cleat component (leg β) is attached to the beam web through bolt group β .

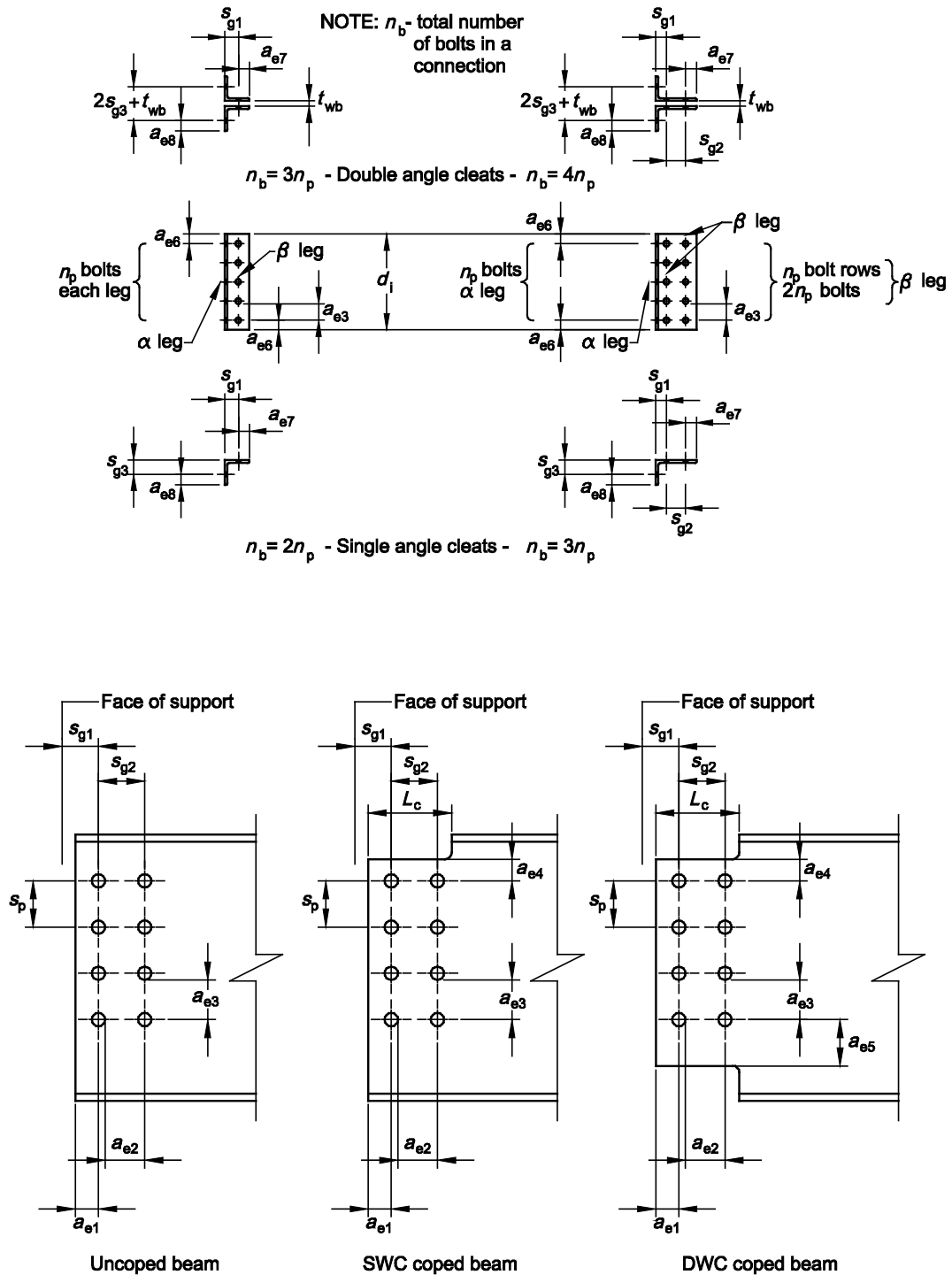

FIGURE 11 CONNECTION GEOMETRY

RECOMMENDED DESIGN MODEL – SUMMARY OF DESIGN CHECKS

Single and double angle cleats

Design is based on determining V_{des} , the design capacity of the connection, which is the minimum of the design capacities tabulated below.

The design requirement is then $V_{des} \geq V^*$ (design shear force).

From AS 4100, Clause 9.1.4(b)(ii) (Ref. 7) this connection must be designed for a minimum design shear force of 40 kN, or $0.15 \times$ member design shear capacity, whichever is the lesser.

DESIGN CHECK NO. 1	— Detailing limitations
DESIGN CHECK NO. 2	— Design capacity of bolts to supporting member
DESIGN CHECK NO. 3	— Design capacity of bolts to supported member
DESIGN CHECK NO. 4	— Design capacity of angle cleats (Shear, bending, block shear)
DESIGN CHECK NO. 5	— Design capacity of supported member (Shear—Uncoped or coped)
DESIGN CHECK NO. 6	— Design capacity of supported member (Block shear—Coped section)
DESIGN CHECK NO. 7	— Design capacity of supported member (Bending of coped section)
DESIGN CHECK NO. 8	— Beam rotation check
DESIGN CHECK NO. 9	— Local stability of coped supported member
DESIGN CHECK NO. 10	— Local capacity of supporting member

The full design checks are documented in Ref.14. Design capacity tables for common standardised configurations of bolted angle cleats are provided in Ref.14, together with detailing aspects.

ASI RECOMMENDATIONS

ASI recommends that the supply chain, and in particular designers, fabricators and detailers, explore at an early stage in the project the cost savings possible through sympathetic detailing of the connections with consideration given to both the capabilities of the distribution chain to provide cost effective pre-processing and the availability of CNC machines in some fabrication shops. The use of the bolted angle connection may be a cost effective solution in some situations.

Designers should facilitate the potential adoption of alternative solutions for connection configuration, where these meet the performance requirements and can be demonstrated to provide cost and/or time efficiencies. The bolted angle connection is a case in point. Notes on the relevant construction drawings or in specifications to allow submission of alternative solutions may be an appropriate mechanism.

Compliance of construction products is a current issue in industry. In respect of steelwork, the engineer must have confidence in the material systems and traceability, weld processing capability to AS/NZS1554 etc. of the fabricator, appropriate to the level of risk for the structure concerned. These systems are covered by the ASI National Structural Steelwork Compliance Scheme (NSSCS) and the ASI Structural Steelwork Fabrication and Erection Code of Practice (COP). At the time of writing, the COP is in process to become the first Australian Standard for fabrication and erection of structural steelwork, AS/NZS 5131. ASI recommends the construction specifications and drawings for all projects contain the wording to reference the new COP (and AS/NZS 5131 when available). Guidance on the required wording is contained in ASI Tech Note TN-011 (Ref. 15), freely downloadable from the ASI website.

REFERENCES

1. Australian Procurement and Construction Council, '*Procurement of construction products. A guide to achieving compliance*', 2014.
2. Australian Steel Institute, '*Structural steelwork fabrication and erection Code of Practice*', Australian Steel Institute, 2014.
3. Steel Compliance Australia website: www.scacompliance.com
4. Rider Levett Bucknall, '*Review of steel costs in medium rise steel framed buildings*', 2011. Download: <http://steel.org.au/key-issues/multilevel-buildings/steel-costs/>
5. Australian Steel Institute, '*Design capacity tables for structural steel, Vol 3: Simple connections - Open sections*', 2007.
6. Australian Steel Institute '*Design capacity tables for structural steel, Vol 4: Rigid connections - Open sections*', 2009.
7. Standards Australia, AS 4100-1998 '*Steel structures*' (includes Amendment 1, 2012).
8. American Institute of Steel Construction, '*Steel construction manual*', 13th edition, 2005.
9. Australian Steel Institute, '*Handbook 1: Design of structural steel connections*', 2007.
10. Steel Construction Institute and British Constructional Steelwork Association, '*Joints in steel construction: Simple connections*', Publication P212, 2002.
11. Carrato, P.J., '*A comparison of Australian and American design of double angle connections*', Engineering Journal, American Institute of Steel Construction, 3rd Quarter, 2003, pp.139–147.
12. Australian Institute of Steel Construction, '*Design of structural connections*', 4th edition, Authors Hogan, T.J. and Thomas, I.R., 1994.
13. American Institute of Steel Construction, '*Manual of steel construction load and resistance factor design*', 3rd Edition, 2001.
14. Australian Steel Institute, '*Design guide 5: Angle cleat connections*', 2007.
15. Australian Steel Institute, Tech Note TN-011 '*Structural steelwork fabrication and erection Code of Practice – Implementation guide for design engineers*', Oct, 2014.